



Collezione porte  
**LINEA FANTASY**



Versione 0017



AZIENDA CON SISTEMA DI QUALITÀ  
CERTIFICATO UNI EN ISO 9001





## LA NOSTRA AZIENDA

Sin dal 1976 la nostra azienda si dedica alla progettazione e produzione di porte di altissimo pregio, dagli elevati valori prestazionali e in una vasta gamma di modelli, finiture, essenze e laccati.

Costruite attraverso sistemi tecnologici all'avanguardia, le porte Il Legno si distinguono per gli elevati standard qualitativi caratteristici delle lavorazioni artigianali Made-in-Italy, grazie a cui è possibile realizzare prodotti esclusivi e su misura, a seconda delle esigenze del cliente, in grado di unire design, funzionalità, sicurezza ed affidabilità a lungo termine.

La selezione delle migliori materie prime nel pieno rispetto dell'ambiente, la consulenza tecnica fornita da esperti e la puntualità del servizio sono i principali fattori che nel corso del tempo hanno contribuito a rafforzare una filosofia aziendale basata sulla piena soddisfazione del cliente.

Le porte Il Legno sono in grado di armonizzarsi a qualsivoglia tipologia di ambiente, stile d'arredamento o preferenza estetica grazie all'ampio ventaglio di materiali, finiture e accessori offerti, ciascuno dei quali si contraddistingue per qualità e cura nei dettagli, entrambi elementi cardine nella realizzazione di ogni singolo prodotto.

La produzione Il Legno è inoltre completata da armadiature, complementi d'arredo e boiserie su misura, che consentono di realizzare ambienti dall'elevato valore funzionale ed estetico.



## COLLEZIONE "LINEA FANTASY"

**Telaio** lavorato in legno listellare spessore mm. 40 raggio 3 con battuta, guarnizione, fresate per incastro coprifili.

**Coprifili** in multistrato da 70x10 al lato cerniere, coprifilo da 90x10 al lato bello porta, entrambi con aletta ad incastro.

**Ante** spessore mm. 44 con massello perimetrale in abete giuntato FJ per eliminare i nodi e risacche di resina, supporti in MDF da mm. 4, alveolare in cartone resinato pesante a foro 20/25, tappi di rinforzo altezza serratura. Le massellate sono realizzate con montanti e traverse in **legno listellare**, per entrambe le soluzioni il tutto è rivestito in laminato antigraffio da campionario. Ante con battuta tre lati bordate in tinta.

**Ferramenta** cromo satinato, cerniere anuba da 14, tre per anta, serratura patent meccanica.

**A richiesta:** serratura magnetica. Possibili cerniere a scomparsa 3D, tre per anta in tutte le finiture.

**Finitura New Agata cerniere a scomparsa 3D. di serie.**

*\* Le tonalità del colore presenti nel catalogo non sono vincolanti ai fini della fornitura delle porte stesse, in quanto riportate con un procedimento di stampa.*

**Il Legno produce anche porte ACUSTICHE CERTIFICATE e porte REI CERTIFICATE, realizzate con la maggior parte delle finiture presenti in questo catalogo.**

***DA UN AMBIENTE  
ALL'ALTRO  
CON "IL LEGNO"***

 521  
DEA



*\*Vedi tutte le varianti compositive della serie  
TAMBURATE a pagina 30.*

521  
ERA 



**QUALITÀ ARTIGIANALE  
PER UN ARREDAMENTO  
ESCLUSIVO.**

521  
REGINA



*\*Vedi tutte le varianti compositive della serie  
TAMBURATE a pagina 30.*



521  
NEW AGATA 



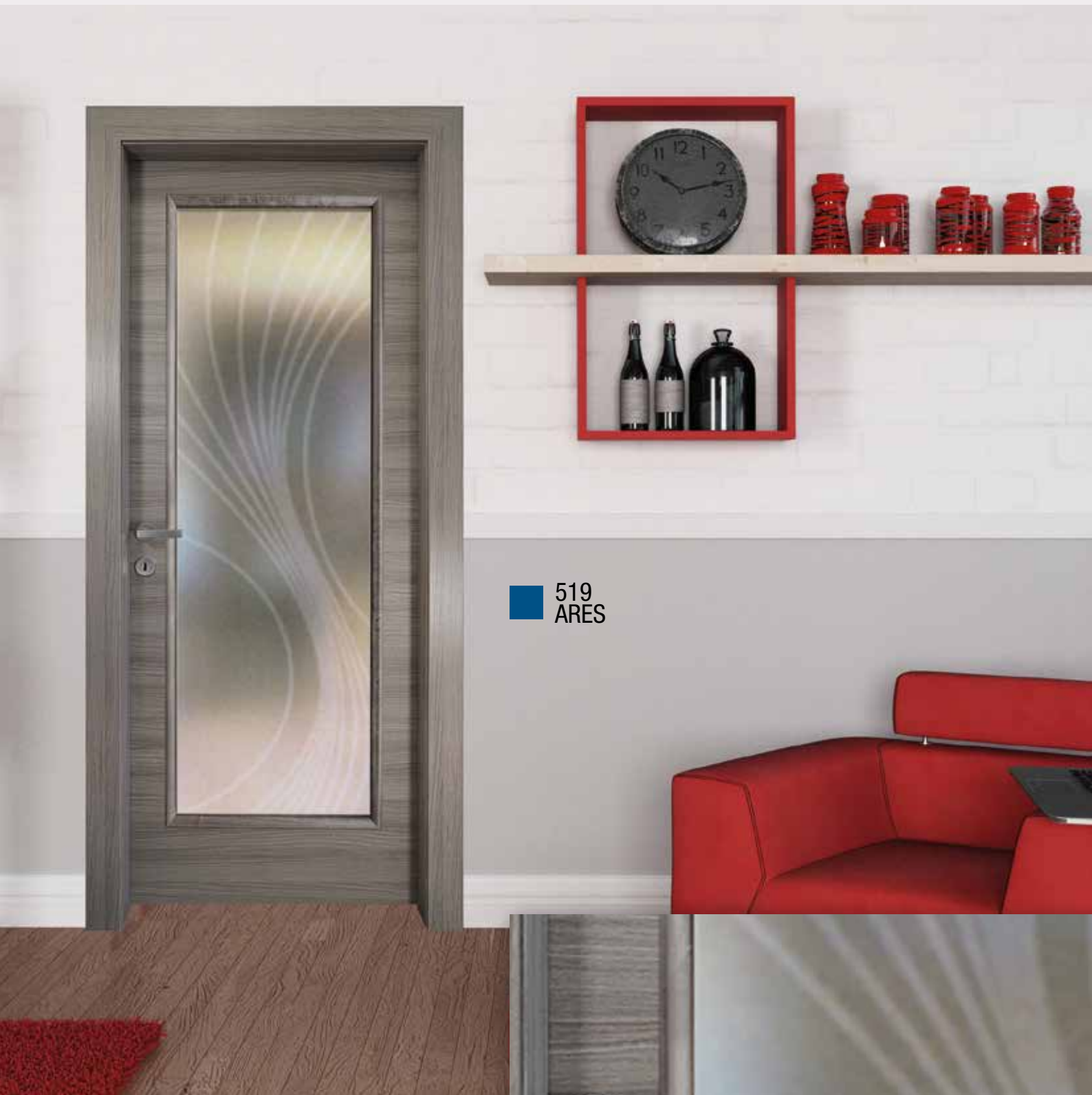

■ 519  
ARES



*\*Vedi tutte le varianti compositive della serie  
TAMBURATE a pagina 30.*

532  
EROS 







521  
CHLOE



521  
LUNA 





■ 521  
NETTUNO



■ 521 EROS

*\*Vedi tutte le varianti compositive della serie TAMBURATE a pagina 30.*



## PROFILI PERSONALIZZABILI

La porta modello 521 della Linea FANTASY, può essere personalizzata tramite l'inserimento di profili lineari in alluminio, posizionati a scelta del cliente tra le seguenti varianti:

12



a



b



c



d



e



f

521  
ARES



g



h



i

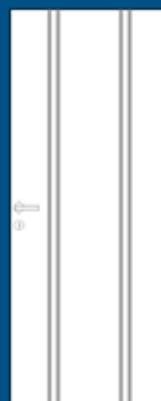

l

SOLUZIONI A  
SCELTA PER LA  
DISPOSIZIONE  
DEI PROFILI  
IN ALLUMINIO  
STONDATI



m



n



466  
LADY + pannello nero

## ABBINAMENTI CROMATICI

Il modello di porte 466 permette di scegliere una determinata finitura della Linea FANTASY (vedi pag. 27 e 28) per la realizzazione della cornice e dei montanti laterali, abbinandola ad un colore a scelta da applicare sul pannello centrale, con possibilità di laccatura lucida e/o opaca, facendo riferimento alle mazzette RAL e NCS.



14 466  
ARES + pannello arancione



466  
ERA + pannello grigio



**ARMONIA E PRATICITÀ  
IN SOLUZIONI DI DESIGN.**

466  
ERA + pannello rosso



*\* Vedi tutte le varianti compositive della serie MASSELLATE a pagina 31.*



■ 411  
LUNA



■ 426  
LUNA



■ 419  
LUNA







419  
LUNA

---

MODELLI CON LASTRE IN VETRO STRATIFICATO E/O TEMPERATO, DISPONIBILI NELLE SEGUENTI TIPOLOGIE:

- Satinato bianco
- Trasparente
- Bianco latte
- Quadretto
- Sfumato
- Bianco latte extra chiaro
- Ramo
- Riquadro



 **466**  
**LUNA**



 **432**  
**LUNA**

**PIÙ DI UNA SCELTA  
D' ARREDAMENTO:  
UN MODO DI ESSERE.**



419  
LUNA





■ 411  
ERA



■ 419  
ERA



■ 426  
ERA

**ZOCCOLO A SCELTA NELLE  
SEGUENTI VERSIONI:**

- UGUALE su tutti i 4 lati



- DOPPIO rispetto ai restanti 3 lati

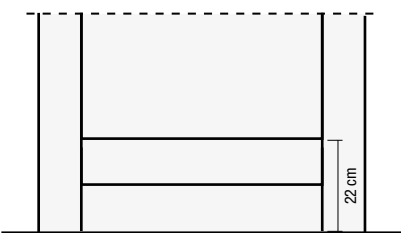

■ 419  
ERA



■ 466  
ERA

**CREAZIONI CHE ESPRIMONO CHI SEI.**

426  
ERA



*\* Vedi le possibili varianti compositive a pagina 31.*



■ 466  
EROS-LUNA



■ 450  
EROS



■ 470  
LUNA

Modelli realizzabili solo su alcune  
finiture di campionario.



419  
ERA-EROS 



*\* Vedi le possibili varianti compositive della serie MASSELLATE a pagina 31.*

419  
EROS



24



419  
EROS



426  
EROS

***ESPRESSIONI  
CREATIVE  
DELL'ESSENZA  
DEL LEGNO.***





## ROTO

Questa tipologia di apertura rototraslante, nata per risolvere i problemi di spazio spesso presenti nelle case moderne, rappresenta una novità geniale: l'innovativo meccanismo si basa sullo spostamento del perno di rotazione della porta che così diventa girevole e apribile in entrambi i sensi, con notevole riduzione del raggio d'apertura. La porta non è più ingombro od ostacolo ma mantiene la sua natura di elemento d'arredo, ora anche più curioso e funzionale.





■ Scorrevole a incasso



■ A libro



■ Scorrevole esterno muro con o senza controbattuta



■ Scorrevole esterno muro con guida in alluminio e pattino a scomparsa (solo nelle versioni cieco/liscio)

# BATTISCOPIA E TELAI IN LEGNO



■ Battiscopa (finitura porte)

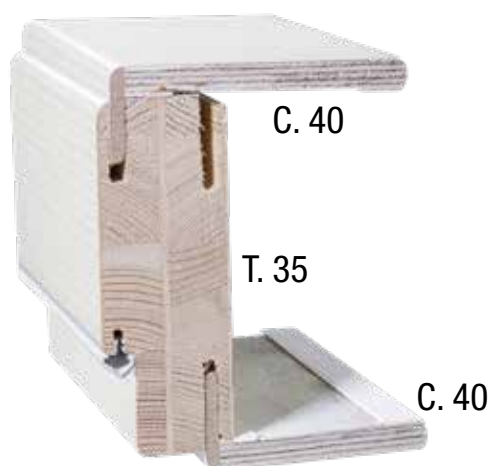

■ Telaio standard + cornice PLUS

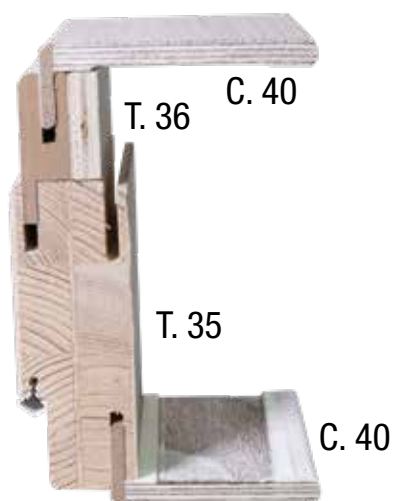

■ Telaio con allargamento + cornice PLUS



■ Kit T. 35 scorrevole

# SISTEMI COSTRUTTIVI



■ Telaio a madonna



■ Massellata



■ Massellata a fodera piana



■ Tamburato



■ Massellata a vetro



**SERRATURA MECCANICA  
+ CERNIERA ANUBA:**  
di serie per tutti i modelli  
della "Linea FANTASY".

Serratura magnetica e  
cerniera a scomparsa 3D  
disponibili su specifica ri-  
chiesta del cliente, con re-  
lativo supplemento.



# SISTEMI DI APERTURA/CHIUSURA E MISURE

Scorrevole incasso sx

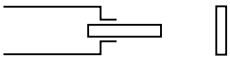

Scorrevole incasso dx

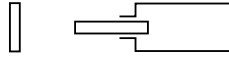

Scorrevole incasso doppia anta

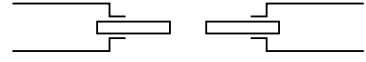

Scorrevole esterno muro sx

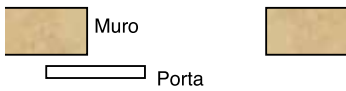

Scorrevole esterno muro dx

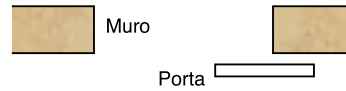

Aumenta lo spazio "Di qua - Di là - Roto"

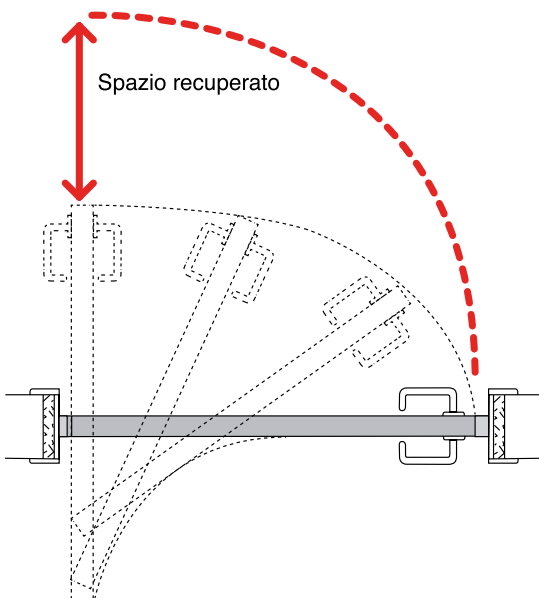

Apertura "via-vai" (saloon)

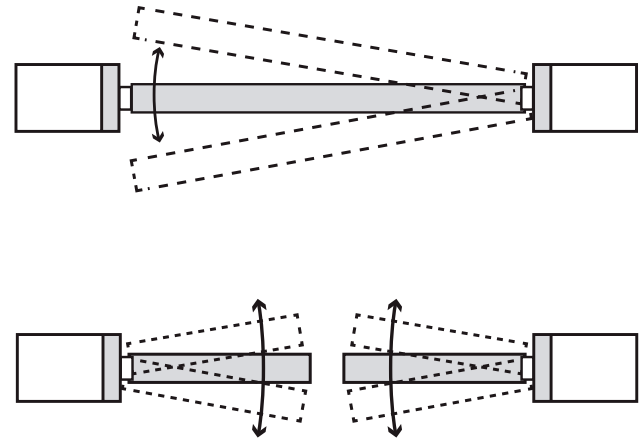

Senso di apertura porta classica

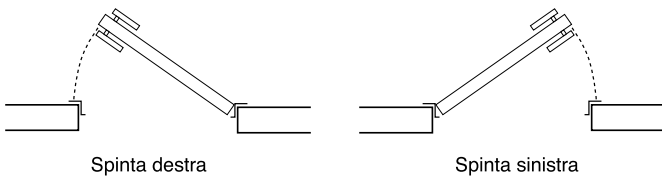

Senso di apertura porta a libro

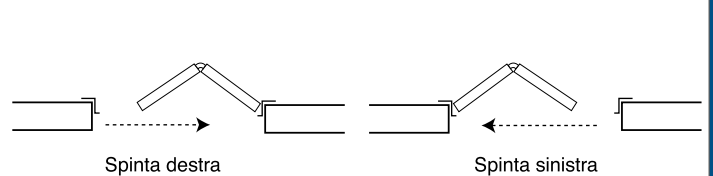

## MISURE STANDARD E A SUPPLEMENTO

Misura foro muro minima: 69 - 74 - 79 - 84 - 89 - 94 - 99 - 109 x 215

Misure passaggio 60 - 65 - 70 - 75 - 80 - 85 - 90 - 100 x 210 x 10,7

Realizzazioni a misura, in doppia anta, con sopra luce e per i modelli lisci è possibile la versione in pendenza.

- Per tutti i modelli della Linea FANTASY la serratura meccanica e la cerniera ANUBA sono di serie.
- È possibile installare le cerniere a scomparsa 3D (su richiesta del cliente con relativo supplemento) solo sulle finiture ERA, REGINA, LUNA, EROS, ARES, DEA e CHLOE.

# VARIANTI COMPOSITE: SERIE TAMBURATE

■ 521



■ 519

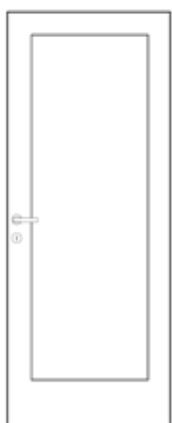

■ 529

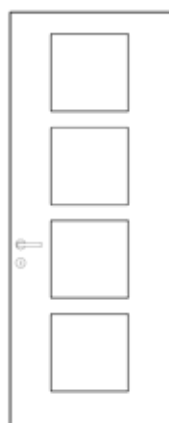

■ 553

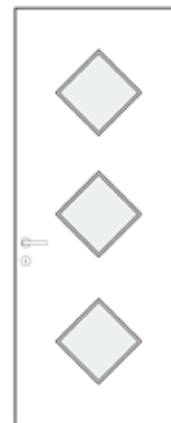

■ 526

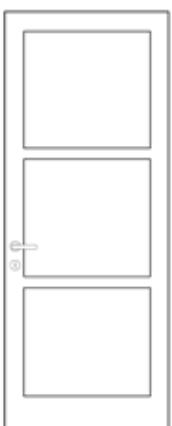

■ 532

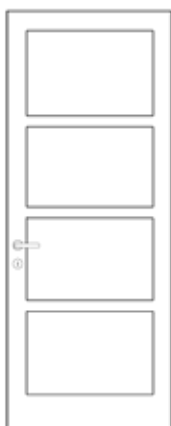

■ 536

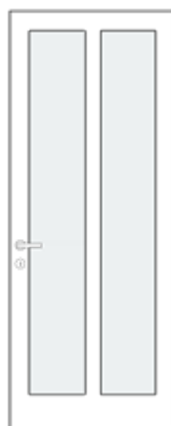
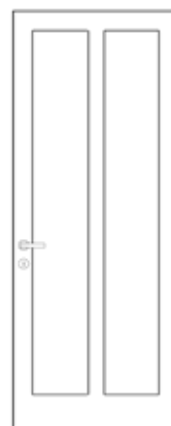

■ 522

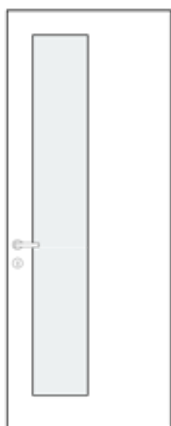

**ZOCCOLO DISPONIBILE  
IN DIVERSE ALTEZZE:**

- 11,5 cm (uguale su tutti i 4 lati)
- 16 cm (11 cm sui restanti 3 lati)
- 23,5 cm (11 cm sui restanti 3 lati)

# VARIANTI COMPOSITE: SERIE MASSELLATE

■ 412



■ 450

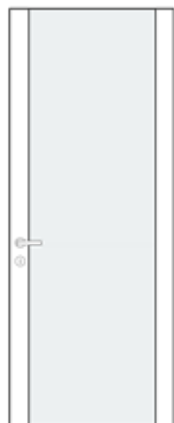

■ 419

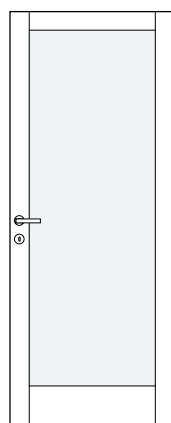
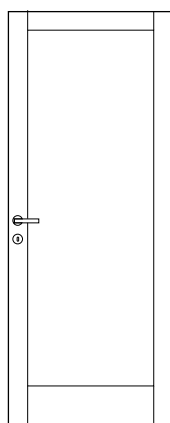

■ 426

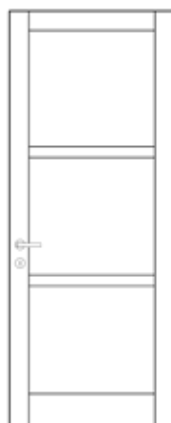

■ 432

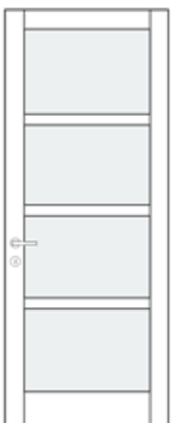
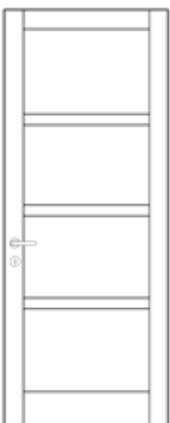

■ 436

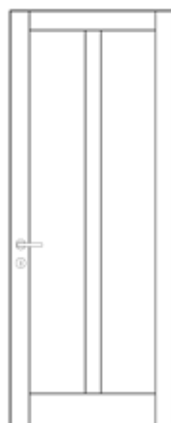

■ 466



■ 470



ERA



REGINA

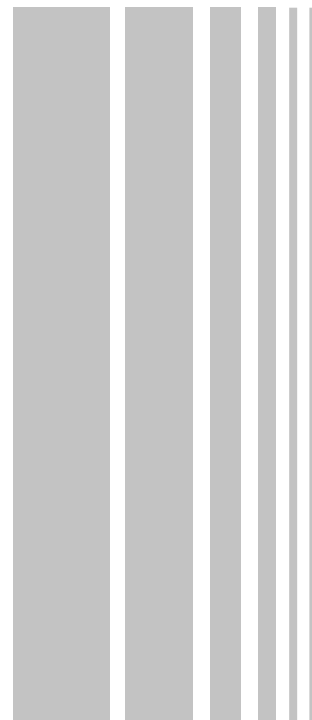

**Tonalità NEUTRE**



DEA



LUNA



NEW AGATA





## Tonalità NATURALI



■ CHLOE



■ ARES



■ NETTUNO



■ EROS

*\* Le tonalità di colore presenti nel catalogo non sono vincolanti ai fini della fornitura delle porte stesse, in quanto riportate con un procedimento di stampa.*

La porta modello 466 della Linea FANTASY, può essere personalizzata su specifica richiesta del cliente con relativo supplemento.

Il pannello centrale può essere laccato opaco in tutte le colorazioni RAL e NCS.

È quindi possibile effettuare abbinamenti cromatici a scelta, tra le svariate finiture in legno e le mazzette colori.



# MANIGLIE



 **ROBOT**



 **MILLA\_LC31**



 **ROBOQUATTRO**



 **ROBOQUATTRO S**



 **ROBOCINQUE**



 **ROBOCINQUE S**



**ELLE**



**ELLESSE**



**TAIPAN**

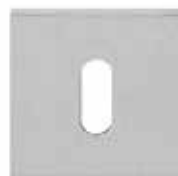

**ALBA**



**ESPRIT**



**FEDRA**



Via Robert Fulton, n.9  
40017 - San Giovanni in Persiceto  
Bologna (ITALIA)

---

Tel. +39 051 6810988  
Tel. +39 051 734959  
Fax +39 051 6811343

[info@italialegno.it](mailto:info@italialegno.it)  
[www.italialegno.it](http://www.italialegno.it)

